

1. THIS DRAWING IS COPYRIGHT, RESERVED AND REMAINS THE PROPERTY OF MONTGOMERY FORGAN ASSOCIATES.  
 2. THE CONTRACTOR AND HIS SUBCONTRACTORS/SUPPLIERS ARE TO VERIFY ALL DIMENSIONS AND LEVELS ON SITE PRIOR TO COMMENCING ON SITE/MANUFACTURE OF GOODS/MATERIALS.  
 3. THE CONTRACTOR IS TO BRING TO THE NOTICE OF THE ARCHITECT ANY DISCREPANCIES CONTAINED IN THIS DRAWING PRIOR TO WORK COMMENCING. WHERE RELEVANT THIS DRAWING IS TO BE READ IN CONJUNCTION WITH ALL RELEVANT DESIGN DRAWINGS AND SPECIFICATIONS.

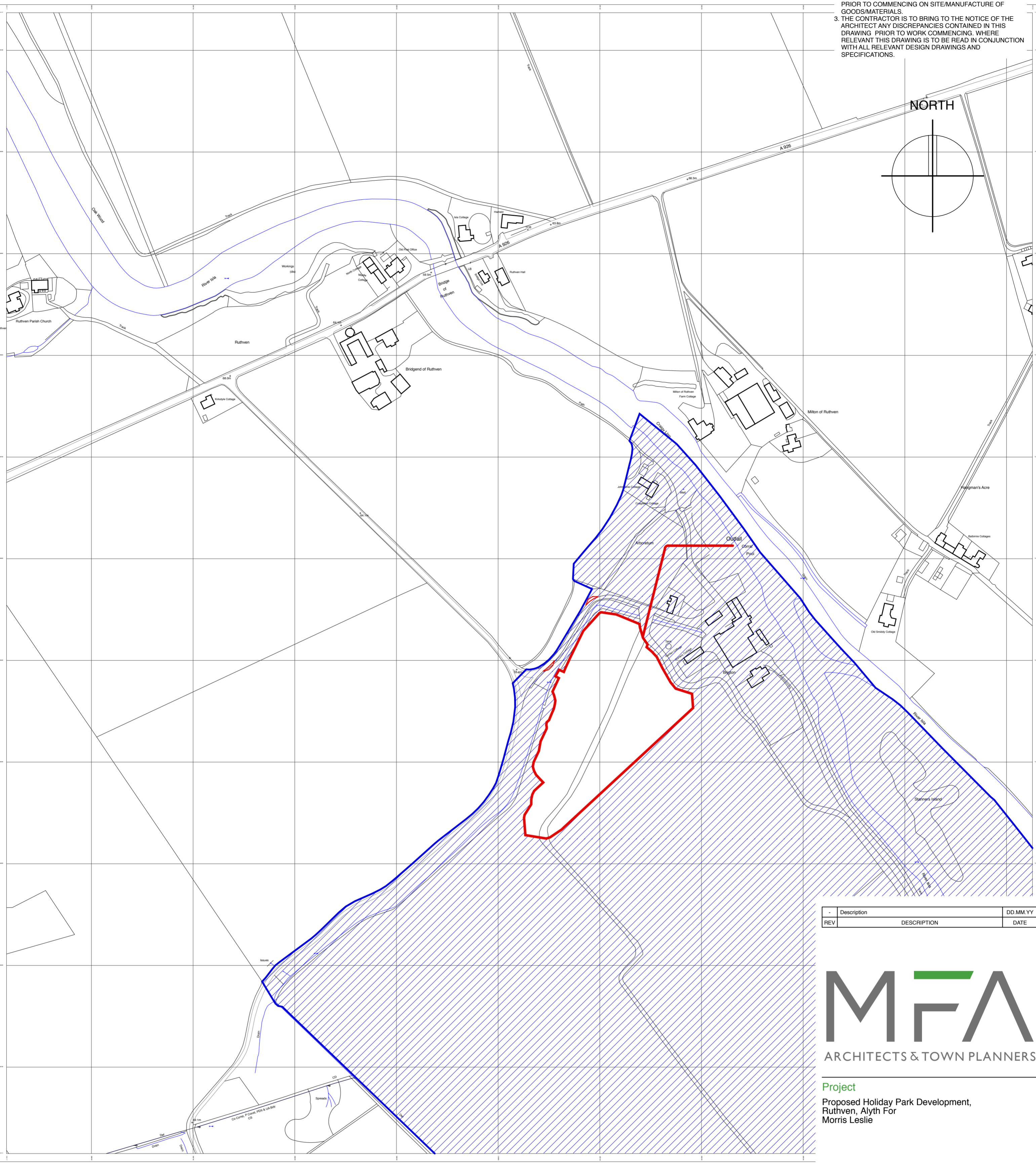

REV	Description	DD.MM.YY
	DESCRIPTION	DATE

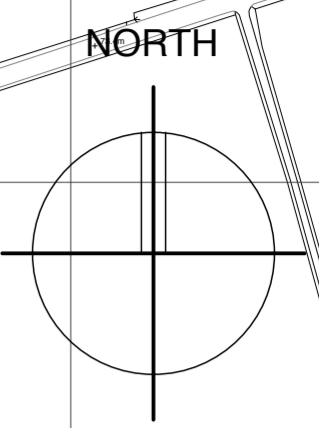

**Project**  
 Proposed Holiday Park Development,  
 Ruthven, Alyth For  
 Morris Leslie

**Drawing**  
 Location Plan

**Date**  
 31/03/2020

**Drawn**  
 AKA

**Scale**  
 1-2500@A2

**Status**  
 Planning

**Drawing Number**  
 5747-C-01

**Revision**  
 -

**Montgomery Forgan Associates**  
 Eden Park House, Cupar, Fife, KY15 4HS  
 Tel: 01334 654936  
 Email: admin@montgomery-forgan.co.uk  
 www.montgomery-forgan.co.uk

©CROWN COPYRIGHT 2020.  
 ALL RIGHTS RESERVED.  
 LICENCE NO. AR100007107

